

FLOTECS
Fluid/Flue solutions[®]

CONTROL VALVES

CONTROL VALVES

BODY STRUCTURE

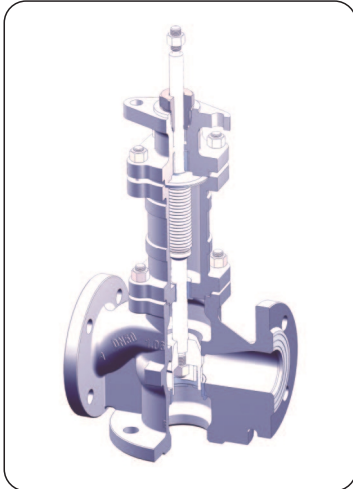

- 1.High strength body to withstand high pressure conditions.
- 2.Meticulous design and control of high precision, it can be up to 50:1. We provide a variety of forms of maintenance free stem seals.
- 3.Optional threaded seat . It can reduce KVS value, which can up to 5 times.
- 4.With standard travel indicator.
- 5.Optional Bellow seal.
- 6.Optional V-type/squirrel-cage valve head.

PNEUMATIC ACTUATORS DP32/33/34/34T

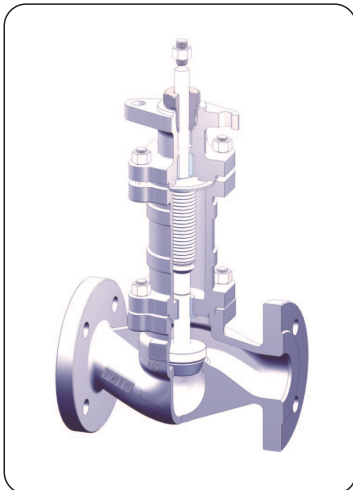

- 1.Multi-spring. Compact Actuators.
- 2.Rotary diaphragm with good enhancing feature
- 3.Can select spring closing force.
- 4.The highest inlet pressure can be up to 6 bar .
- 5.Can be equipped with emergency handwheel.

ELECTRIC ACTUATOR PREMIO 2.2KN/5KN/12KN/15KN

- 1.Use synchronized motor to control precisely.
- 2.With standard 2 torque switch and 1 limit switch.
- 3.Technology sealed electronic components with good shock resistance.
- 4.High protection class Ip65.
- 5.Be connected with various types of bus system.

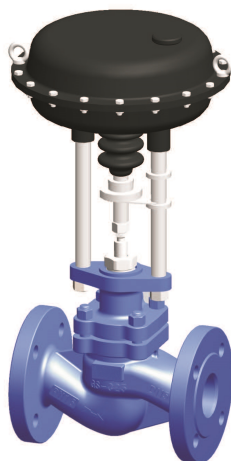

CONTROL VALVES

FLOTECS
Fluid/Flue solutions[®]

www.flotecs.co.uk / sales@flotecs.co.uk

