

**FLOTECS**  
Fluid/Flue solutions®

# Flotecs-Capillary Thermometer-PG

[www.flotecs.co.uk](http://www.flotecs.co.uk) / [sales@flotecs.co.uk](mailto:sales@flotecs.co.uk)

### Temperature measurement

#### Capillary thermometer Standard version

#### Applications

- General-purpose temperature measuring instruments for gaseous, liquid and highly-viscous process media in harsh working environments
- Refrigeration industry

#### Special features

- Scale ranges from -40 ... +600 °C
- Unit single C or F or dual C/F



#### Standard version

- Nominal size in mm: 63mm,100mm,150mm
- Design:BS EN 13190
- Case materials:Stainless steel case and bayonet bezel
- Mount type: bottom with back flange or back mount with front flange
- Stem:diameter 10mm or 12mm, length as requests.
- Stem materials: stainless steel
- Capillary length: 1meter, 3meters, 5meters and so on.
- Accuracy: 2%
- Thread type: 1/2,3/8,3/4 BSP, NPT, BSPT or other standard thread
- IP rate: 66

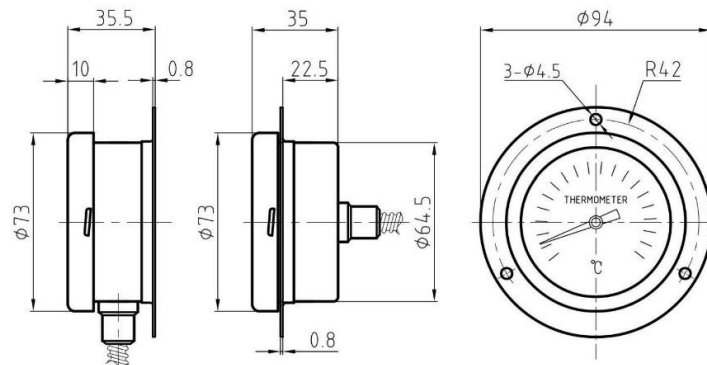

100mm Dial Thermometer - Bottom Entry

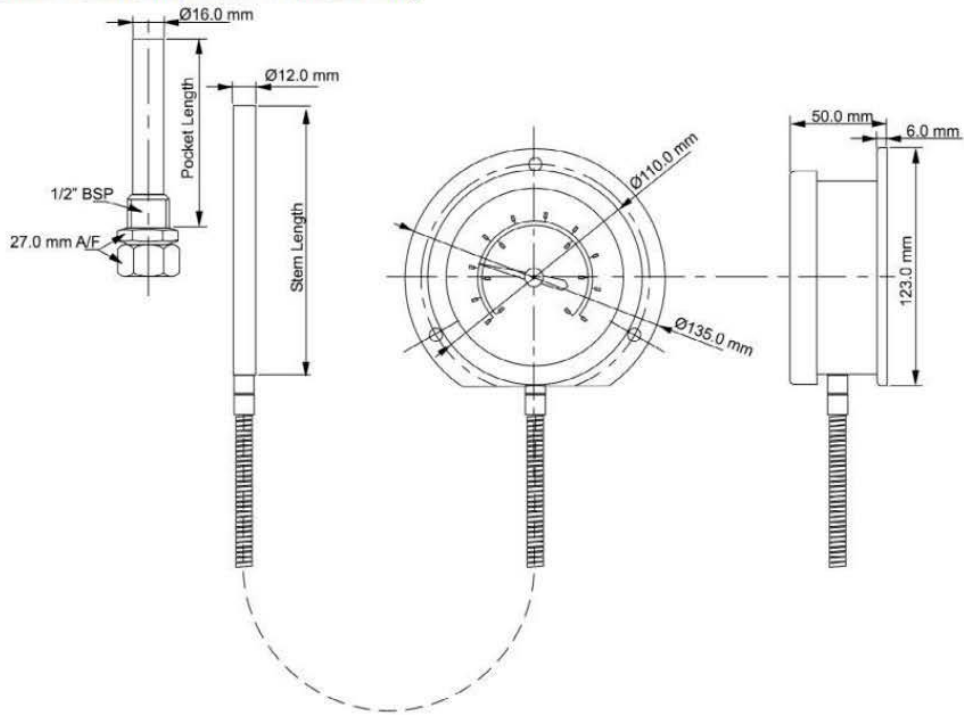

150mm Dial Thermometer - Bottom Entry

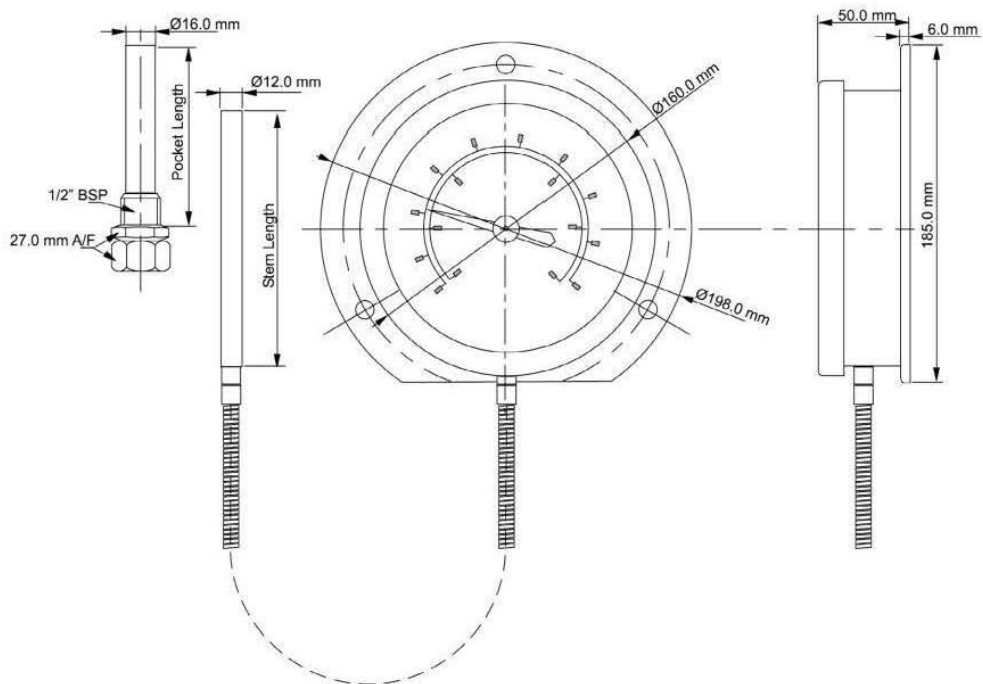

# Flotecs-Capillary Thermometer-PG

**FLOTECS**  
Fluid/Flue solutions<sup>®</sup>

[www.flotecs.co.uk](http://www.flotecs.co.uk) / [sales@flotecs.co.uk](mailto:sales@flotecs.co.uk)

